

Set up of the bucket cart

Rev. #2 - Bucketcart - 70.183





Set the trolley down lengthwise on the floor, for positioning of the arms



Unscrew the wing nuts and bring the right and left arm in maximum position, and tighten the wing nuts again.



Tighten the upper part with the 4 wing nuts. Pay attention that the axle bar is correctly fitted through the cuttings.



Ready mounted



To lift up the tub, press one foot against the axle of the cart.



The two tub mounts have to be completely insert into the grip moulds.



CAUTION !

Be careful while lifting the full tub. Depending on the material to mix, it can be very heavy.



If you are processing **thin-bodied materials** you can pour them out of the tub by applying the locking device:

- Set the trolley down lengthwise on the floor. The tub swings free.
- First set the tub stop to vertical. The hook on the tub holder extends over the edge of the tub and holds it.
- Then turn the tub holder so that its handle is positioned vertically upwards. The tub is now locked.
- Now lift the trolley again slowly. As soon as you have reached a certain angle the material will flow out of the tub.
- Once you have finished pouring, set the trolley down again and release the tub holder and tub stop.

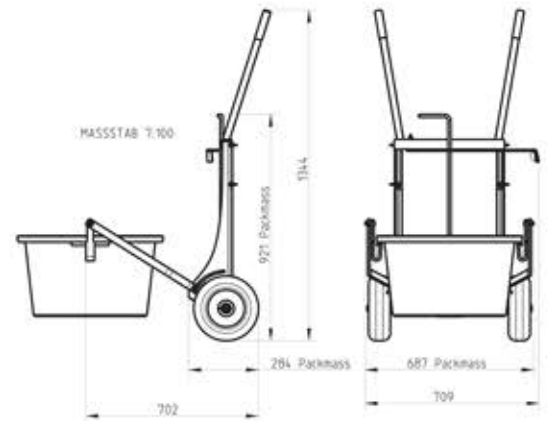
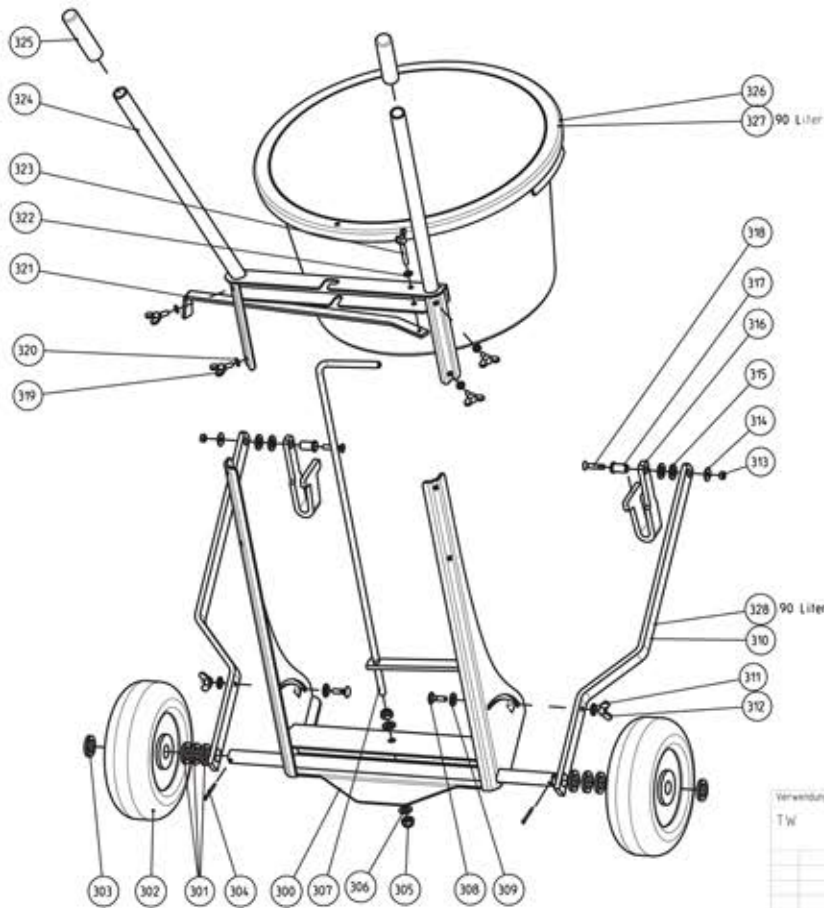

Verwendungsbereich	Collomix	Kollstab 1. DIN-A3 siehe Zeichnung / Stückzahl
T/W		Berücksichtigt, Material Stanzteil Nr. 2 (Zeichnung Nr.) C 05.024.00
	Datum Bearb. 13.10.2006 gpr.	Name Vierbeck
		TRANSPORTWAGEN_65-90_MK2
	Ruete- und Mischgeraete GmbH	Allg. Fertigungstoleranzen nach DIN ISO 2768 m (Ausnahmen siehe Zeichnung)
		Bl von